

KALLER®



*The Next
Generation!*



Controllable Gas Springs - KF2

Controllable Springs - KF2

Introduction

Kaller Controllable Springs (KF2 springs) are a family of gas springs for use in press tools, that can be locked in their bottom position and where the return stroke of the spring can be controlled.

The KF2 springs can be used where, for instance, the blank holder should be locked in its bottom position to avoid deformation of the formed part or when it is beneficial for the transportation of the part.

The Controllable Springs are available as 15 kN, 30 kN, 50 kN, 75 kN springs with stroke lengths from 10 to 160 mm. As the stroke length always has to be fully utilized, the springs can be ordered with any stroke length between 10 and 160 mm (in incremental steps of 1 mm).

For optimal function the full stroke should be used within ± 0.5 mm.

The return stroke of the Controllable Gas Springs is normally controlled using the control system of the press.

The springs can either be installed self-contained or connected to a Control Unit through a hose system. It is recommended that the Controllable Gas Springs are connected to a Control Unit.

When a standard KF2 Gas Spring is locked in its bottom position, a maximum of 1 mm spring-back can be expected before the piston rod comes to a complete stop. If so desired, this spring-back can be fully eliminated by connecting the KF2 spring, through a valve block, to a passive spring (KP). One or more KF2 spring(s) connected to a KP spring is called a positive lock system, KF2 + KP. The two different examples can be seen below.

Complete technical data and CAD drawing templates are available for downloading at www.kaller.com or contact your nearest Kaller distributor for a printed catalog.

Standard Lock, KF2

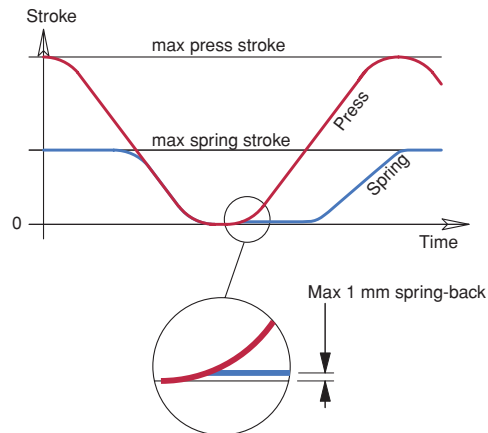

Positive Lock System, KF2 + KP

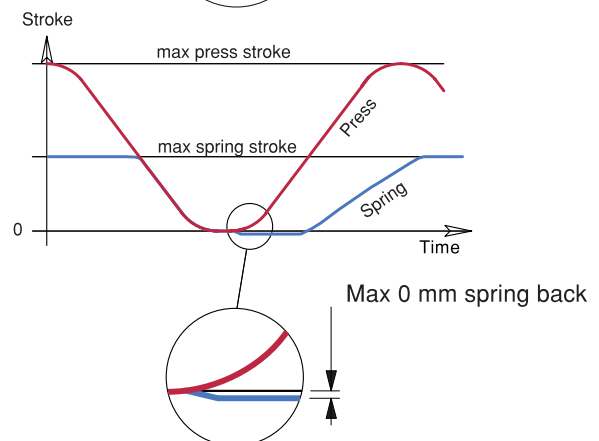
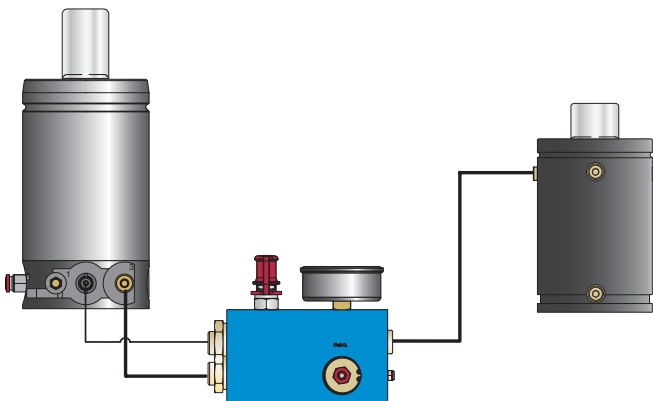

Controllable Springs - KF2

Application example: Standard Lock, KF2

Work cycle

As the upper tool moves downwards, the blank holder (1) will be activated and control the flow of the blank in the tool.

At Bottom Dead Center the KF2 springs will lock. A small spring-back will, in this application, not damage the formed part.

As the press opens, the blank holder will leave the formed part, and the KF2 spring can then be unlocked and eject the part.

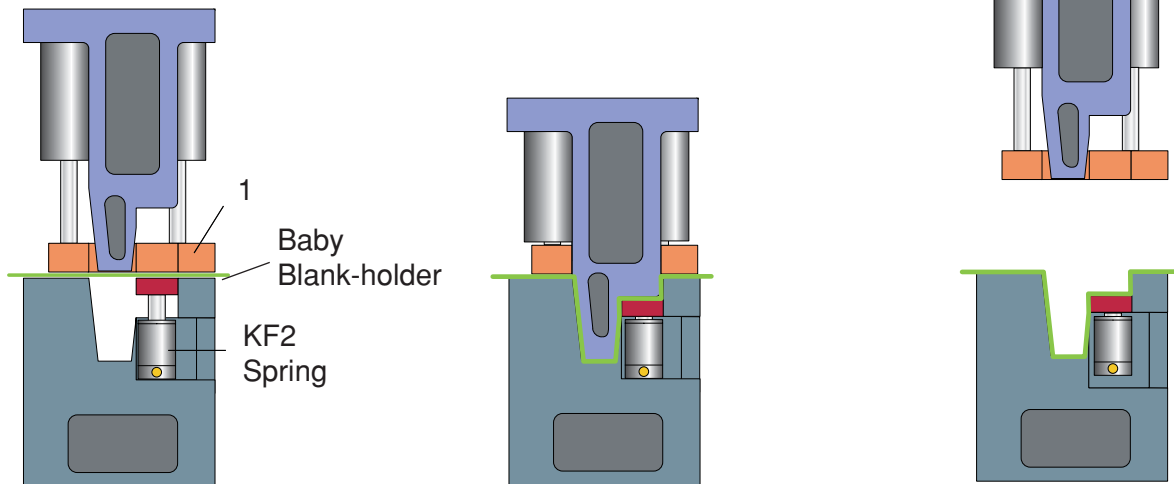

Application example: Positive Lock System, KF2 + KP

Work cycle

The upper tool contains the KF2 controllable gas springs that provide the active blank holding force for the locally situated baby blank holder.

The baby blank holder is the first to hold the blank at the problem area as the tool starts to close.

At press BDC, the valve in the valve block opens and the KP spring is used to ensure zero spring-back in the KF2 springs.

As the tool opens, the KF2 springs remain locked until a signal from the press is given, and the KF2 springs help eject the finished part from the tool.

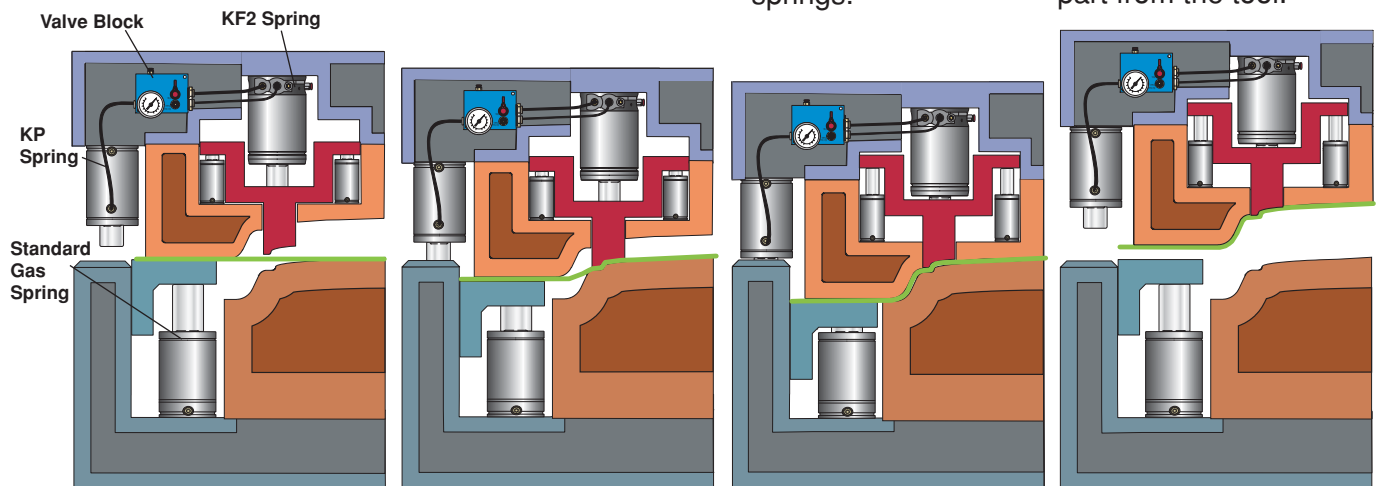

Positive Lock System, KF2 + KP

KALLER®

The Safer Choice

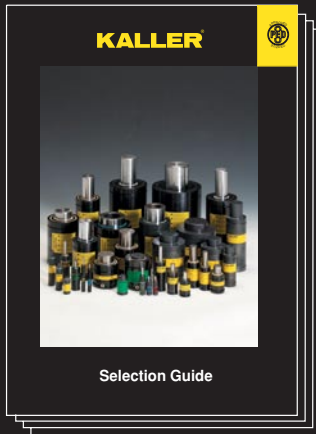

Gas Springs

Kaller developed the first nitrogen gas spring for press tools and today offers a comprehensive selection of high quality gas springs for use in different tool & die applications.



Controllable Gas Springs-KF2

Kaller controllable springs are a family of gas springs, for use in press tools, that can be locked in their bottom position and where the return stroke of the spring can be controlled.



Flange Stripper Unit

Kaller Flange Stripper Unit is used in flanging dies for stripping/lifting a flanged part after forming. It provides 200 daN of stripping force, can be top or bottom mounted and is self guiding.

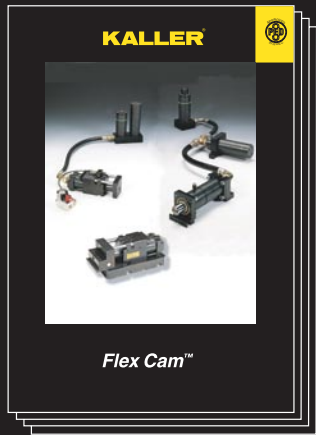

Flex Cam™

The Flex Cam is used for piercing, cutting, forming and flanging operations. The system allows for a flexible distribution of forces with optimal direction and velocity. By using a Flex Cam, fewer tools are required in production.



Roller Cam

Kaller Roller Cam is used for piercing, trimming, flanging and restriking. The Roller Cam can be mounted in both vertical and horizontal angles.

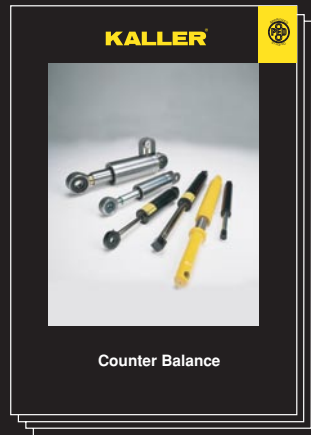

Counter Balance

Kaller Counter Balance gas springs can be used to lift, lower, assist, balance, and hold in a multitude of applications.



33280 Groesbeck Highway
Fraser, MI 48026 USA
Phone: 1-888-200-7190
586-415-6677
Fax: 586-415-6699



For more information see our website
www.kaller.com

©2007 Kaller
June 2007