

KALLER®



Flex Cam™

Introduction

The Flex Cam can be used for piercing, cutting, forming and flanging operations.

The system allows for a flexible distribution of forces with optimal direction and velocity during the operation. Cam Units or Force Cylinders can be coupled together to allow for multiple operations within the same tool to be performed simultaneously. Often by using a Flex Cam, fewer tools are required in production.

The system comprises of a hydraulic Power Unit, Cam Unit/Force Cylinder and interconnecting hoses.

Cam Units are to be used mainly for piercing operations. Force Cylinders are used to drive tooling components such as flanging steels or forming punches.

The Flex Cam is available with the following forces: 15 kN, 40 kN, 60 kN, 90 kN and 150 kN, and with the following stroke lengths: 25, 50, 75, 100, 125, and 150 mm.

The system below consists of a Power Unit and a Cam Unit. On the front face of the cam unit is a punch plate, on which different punches can be mounted. The punch plate is made of unhardened steel to make drilling and tapping easy.

Complete technical data and CAD drawing templates are available for downloading at www.kaller.com or contact your nearest Kaller distributor for a printed catalog.

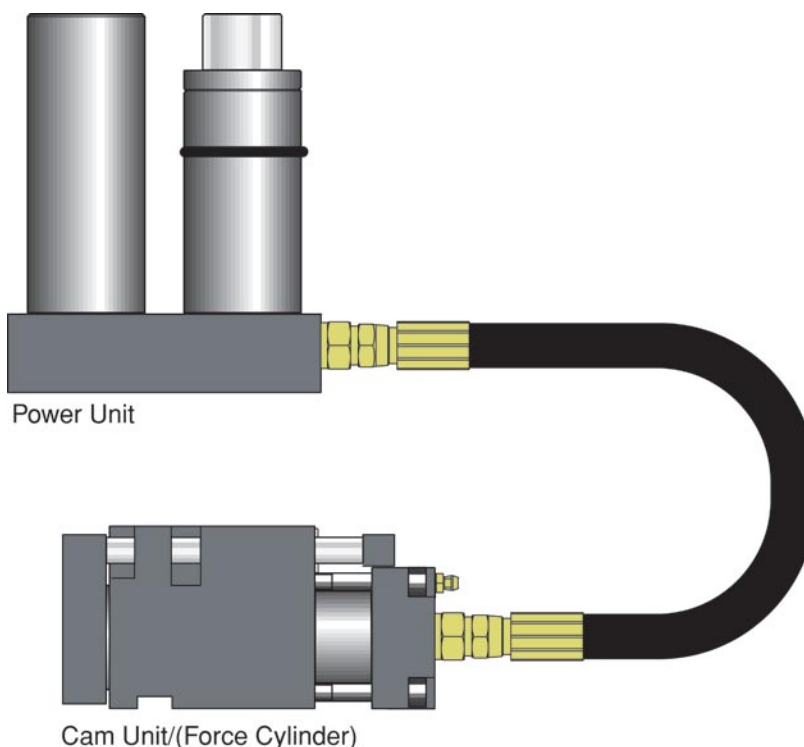

Flex Cam™

Installation examples

Piercing 6 holes

This application uses a hydraulic cam system mounted upside down in the upper tool. The Cam Unit (1) is mounted on a floating die (2). The floating die is centered relative to the lower die using conical pillars and the die is backed up by springs. As the press moves downwards, and the floating die is centered, the Power Unit (3) is activated and the holes are punched.

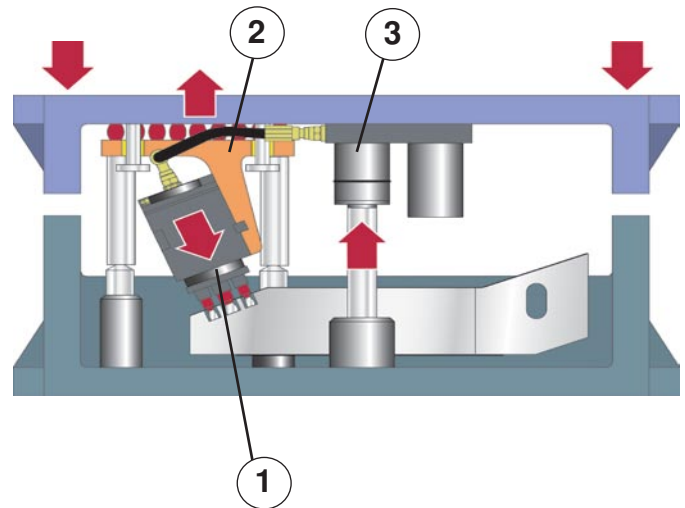

Prior to the installation of the hydraulic cam system, the holes were being punched at a vertical angle using oval shaped punches.

The production and quality enhancements, as a result of the installation of the Flex Cam, resulted in a payback time of three months for the system, including installation.

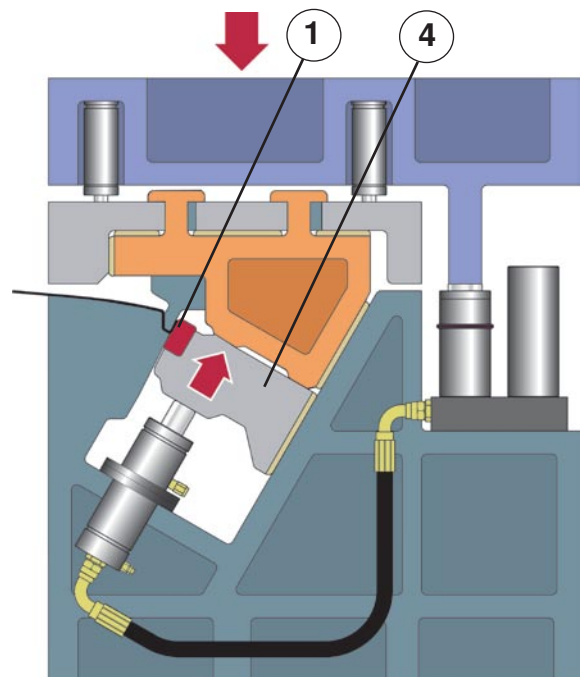

Flanging a wide edge

In this tool two Force Cylinders are being used to drive a 800 mm wide flanging steel. As seen in the picture, the flanging (1) is carried out at an angle opposite to the direction of the press motion.

To ensure a parallel movement at both ends of the flanging steel, two separate cam systems are being used. Each system contains a Power Unit (2) and a Force Cylinder (3).

The flanging steel (4) is well guided in the tool and the Force Cylinders are only subject to axial forces.

Using the Flex Cam has simplified the design of the tool and therefore also reduced the tooling cost.

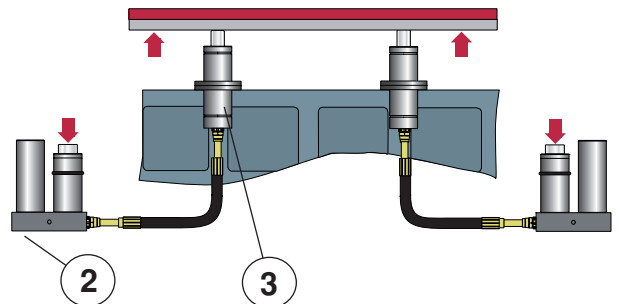

KALLER®

The Safer Choice

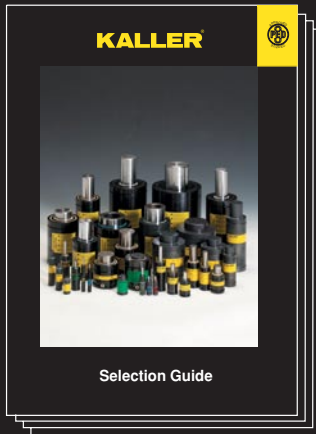

Gas Springs

Kaller developed the first nitrogen gas spring for press tools and today offers a comprehensive selection of high quality gas springs for use in different tool & die applications.



Controllable Gas Springs-KF2

Kaller controllable springs are a family of gas springs, for use in press tools, that can be locked in their bottom position and where the return stroke of the spring can be controlled.



Flange Stripper Unit

Kaller Flange Stripper Unit is used in flanging dies for stripping/lifting a flanged part after forming. It provides 200 daN of stripping force, can be top or bottom mounted and is self guiding.

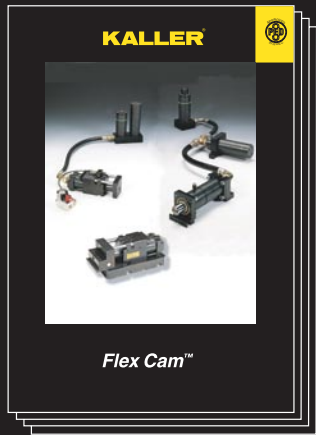

Flex Cam™

The Flex Cam is used for piercing, cutting, forming and flanging operations. The system allows for a flexible distribution of forces with optimal direction and velocity. By using a Flex Cam, fewer tools are required in production.



Roller Cam

Kaller Roller Cam is used for piercing, trimming, flanging and restriking. The Roller Cam can be mounted in both vertical and horizontal angles.

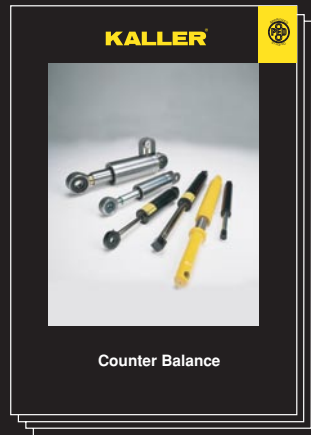

Counter Balance

Kaller Counter Balance gas springs can be used to lift, lower, assist, balance, and hold in a multitude of applications.



33280 Groesbeck Highway
Fraser, MI 48026 USA
Phone: 1-888-200-7190
586-415-6677
Fax: 586-415-6699



For more information see our website

www.kaller.com

©2007 Kaller
June 2007